

CHESTERTON®

ISO 9001
CERTIFIED

Mechanical Seals for Mixer Applications



- Meet the unique challenges of mixer sealing.
- Patented technologies to ensure reliability.
- Models to meet all application ranges.
- Zero emission models, including gas-lubricated 4410 gas seal.
- Service range including Chemical, Pharmaceutical, Food and Beverage.
- For plantwide sealing of mixers, agitators and specialty equipment.

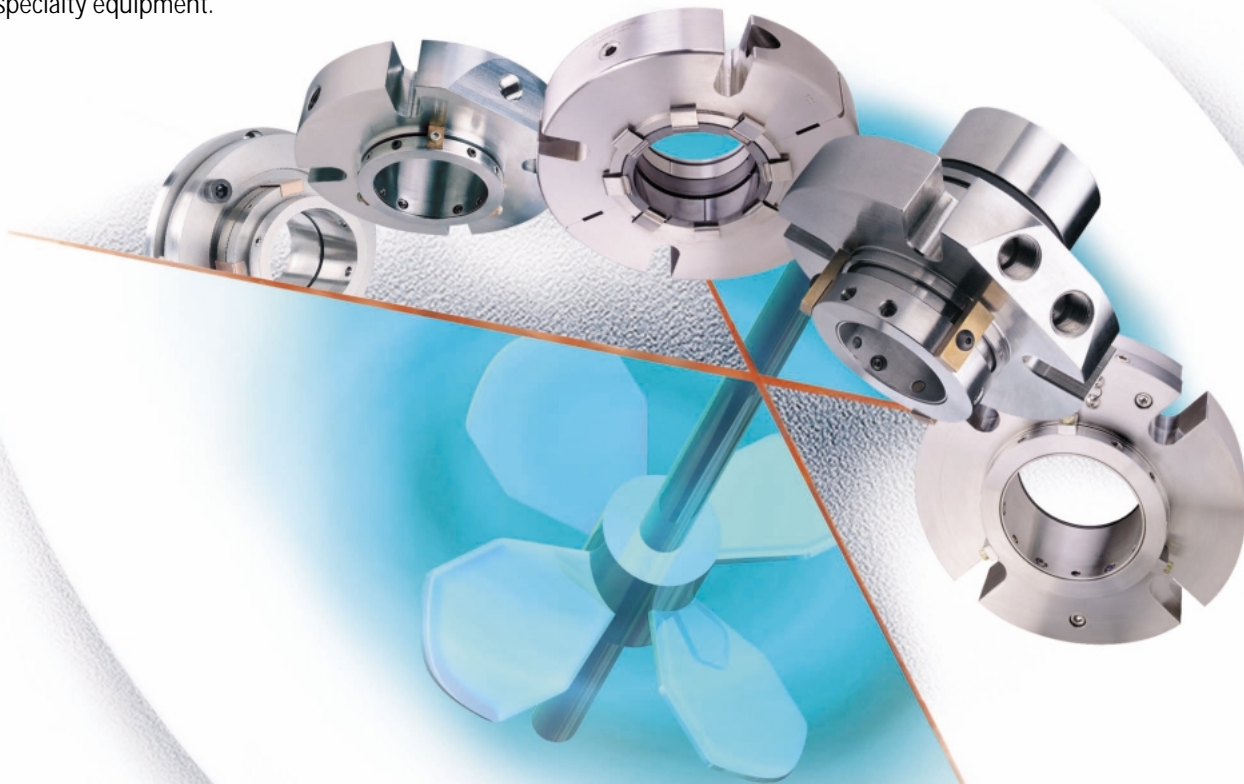

A complete line of shaft seals specifically designed for mixers and specialty equipment

CHESTERTON®

Mechanical Seals for Mixers, Agitators and Other Specialty Applications

The complete line of seals for the full service range. All capable of withstanding the rigors of mixer and agitator service.

Seals designed to accommodate:

- Shaft motion.
- Stop-start cycling.
- Pressure reversals.
- The potential for dry running.
- Sanitary requirements.

All designs can be easily customized to fit your equipment and application.

The Single Seal Choice for Upgrading Equipment: 180M™ Cartridge Seal

CHESTERTON 180M Cartridge Single Seal is the perfect step up. Cartridge design eliminates the common installation and handling issues of component seals. Ingenious design features deliver excellent reliability. Patented features ensure precise installation in the field.

Pressures:
Vacuum to
400 psig/26 barg*
Temperatures to:
550F/260C
Shaft Sizes:
1.750"/45mm to
4.500"/114mm

**When you see CHESTERTON,
you see the future of sealing.**

The Economical Choice: 440M™ Component Single Seal

CHESTERTON 440M Single Seal is the ideal choice for simple, reliable, cost-effective shaft sealing. Outside sealing design allows visual check of face wear. Optional labyrinth design with purge meets needs of sanitary applications.

Pressures:
Vacuum to 100 psig/6.6 barg*
Temperatures to: 550F/260C
Shaft Sizes:
1.500"/38mm to 4.00"/100mm

* Maximum pressure capability is dependent on shaft size. Please contact Chesterton for more information.

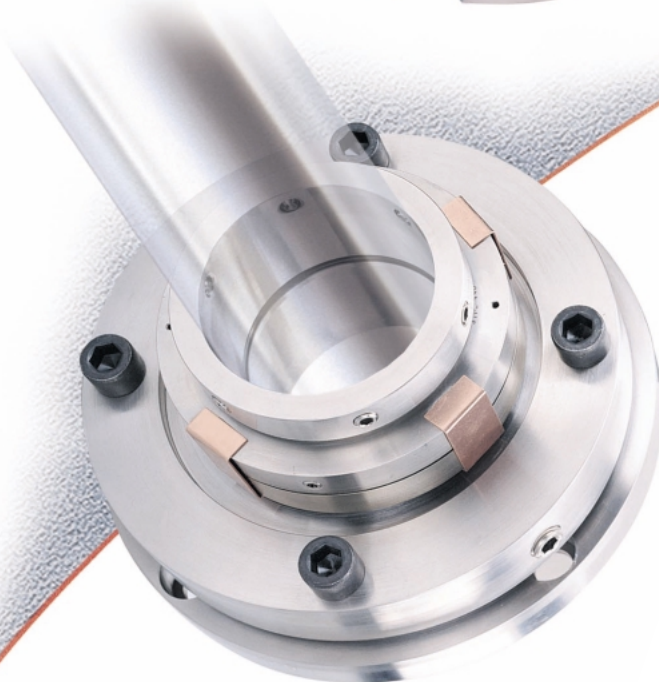

Total Containment with No Risk of Contamination: 4410™ Hydrostatic Gas Seal



The CHESTERTON 4410 Hydrostatic Gas Seal is a revolution in gas seal technology. This coaxial, coplanar, gas lubricated dual seal offers the total containment and zero emission capability of conventional dual seals, but without risk of barrier fluid intrusion into the vessel. Operates from low to elevated speeds equally well, and with virtually no face wear and no resulting particulate contamination. The best new technology for hazardous, highly reactive or sanitary product.

Pressures: Vacuum to 300 psig/20 barg*

Temperatures to: 550F/260C

Shaft Sizes: 2.625"/65mm to 8.00"/200mm

The Universal Choice for Plantwide Services: 442M™ Split Seal

CHESTERTON 442M Split Seal features performance equal to or better than conventional cartridge single seals, but in a split configuration for rapid, high efficiency installation. Withstands elevated pressures and vacuum, including shifts between both extremes. If equipment disassembly is troublesome or time consuming, the 442M is designed to remedy the agony of mixer seal installation.

Pressures:

Vacuum to 225 psig/15 barg*

Temperatures to: 250F/120C

Shaft Sizes:

1.500"/38mm to 7.50"/190mm

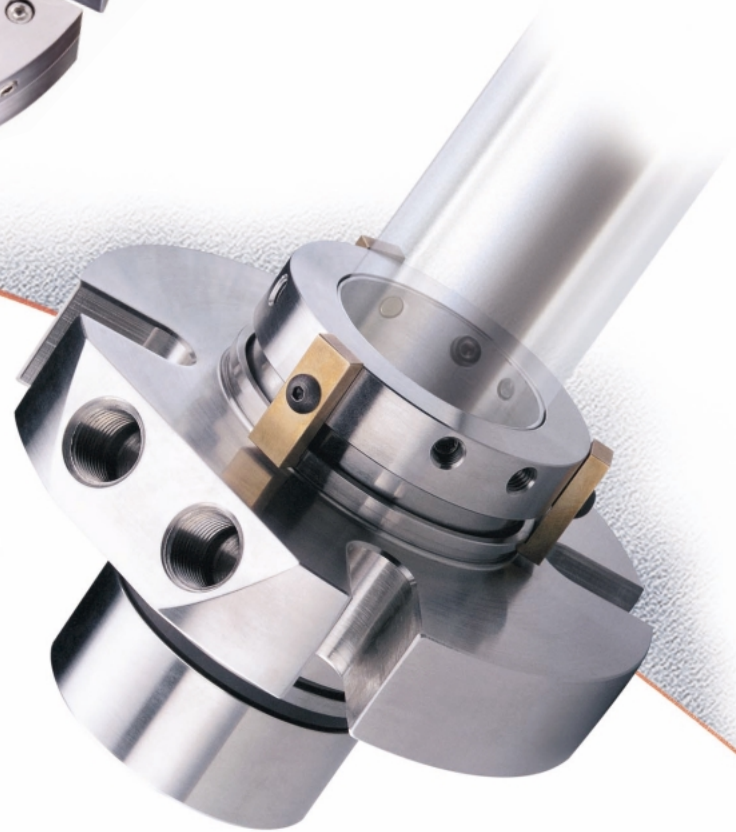

Total Containment in a Robust Package: 280M™ Cartridge Dual Seal

The CHESTERTON 280M Cartridge Dual Seal is designed for total containment of product and emissions. Uses a compatible liquid barrier fluid which can be at higher or lower pressure than process. Provides zero emission capability. Multiple patented features ensure reliability. Available with force circulated barrier fluid system for the most arduous applications.

Pressures: Vacuum to 600 psig/40 barg*

Temperatures to: 550F/260C

Shaft Sizes: 2.625"/65mm to 8.00"/200mm



CHESTERTON®



Inflatable Safety Seal™

The 442M can be coupled with Chesterton's ISS device for an extra measure of reliability in side and bottom entering applications. These 2 products combine to offer an extra measure of reliability in sealing critical, costly product batches. If the seal needs to

be rebuilt in mid-process, the ISS can be inflated on a static shaft to seal the process fluid while the seal is rebuilt. There is no need to drain the tank to rebuild the seal.

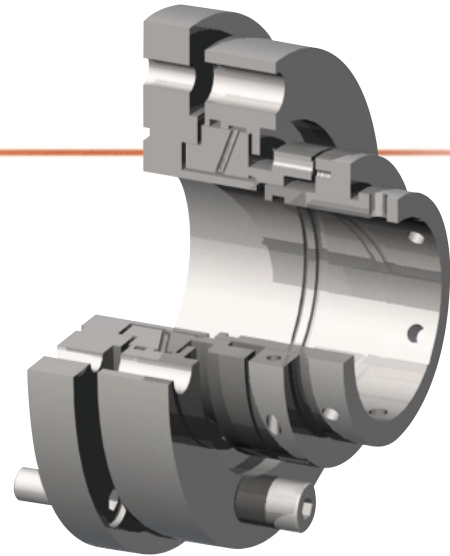
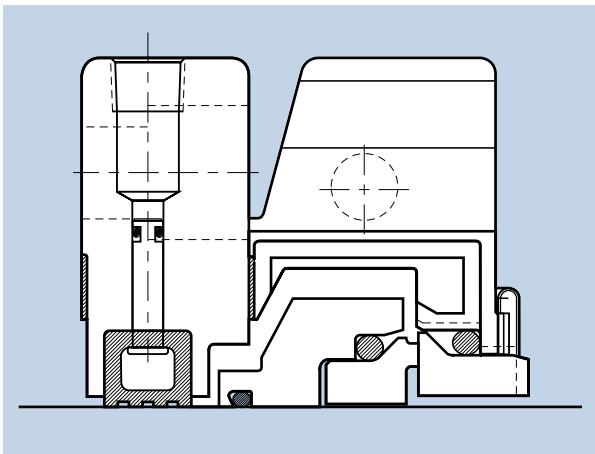

440M and Labyrinth Combination

The 440M can be combined with a sanitary labyrinth and purge arrangement in applications where minimal particulate contamination is required.

Customization for any Application

Chesterton sealing devices can be customized to meet most any need. Contact your local Chesterton representative and allow us to engineer a solution for your custom application.

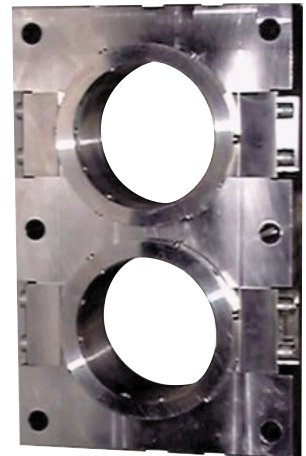

Custom Configuration 4410 Seal for Extruder application

A. W. CHESTERTON CO.

Middlesex Industrial Park, 225 Fallon Road
Stoneham, Massachusetts 02180-9101 USA
Telephone: 781-438-7000
Fax: 781-438-8971
Web Address: www.chesterton.com

© A.W. CHESTERTON CO., 1999. All rights reserved.
® Registered trademark owned and licensed by
A.W. CHESTERTON CO. in USA and other countries.

DISTRIBUTED BY:

FORM NO. 070657

PRINTED IN USA 6/99